



# Heat Transfer Equipment For The Food & Chemical Industries



## Advantage Manufactures A Wide Range of Heat Transfer Equipment Used In Industrial Processing Applications

• **Temperature Control Units**  
Water & Oil  
30° - 500°F

• **Portable Chillers**  
Air & Water-Cooled  
20° - 80°F

• **Central Chillers**  
Air & Water-Cooled  
Packages & Modules  
20° - 70°F

• **Pump Tank Stations**  
Chilled or Tower Water  
200 - 3600 gallons

• **Cooling Tower Cells**  
45 - 540 tons

• **Filters**

• **Heat Exchangers**

### CUSTOM UNITS

If one of our standard models does not meet your application needs, then we can custom build a unit that will! Call us at 317-887-0729 for more details.



### • Beverage Production

- Wineries
- Fermentation Process
- Breweries
- Distilleries

### • Food Production

- Dough
- Chocolate
- Candies
- Dairy

### • Personal Care Products

- Hair Products
- Lotions
- Make Up

### • Chemical Processing

- Drying
- Mixing
- Blending



Heat Exchangers

Evaporative Cooling Towers

Portable Chillers

Pump Tank Stations

Temperature Control Units

Central Chillers



## Heat or Cool Industrial Jacketed Vessels

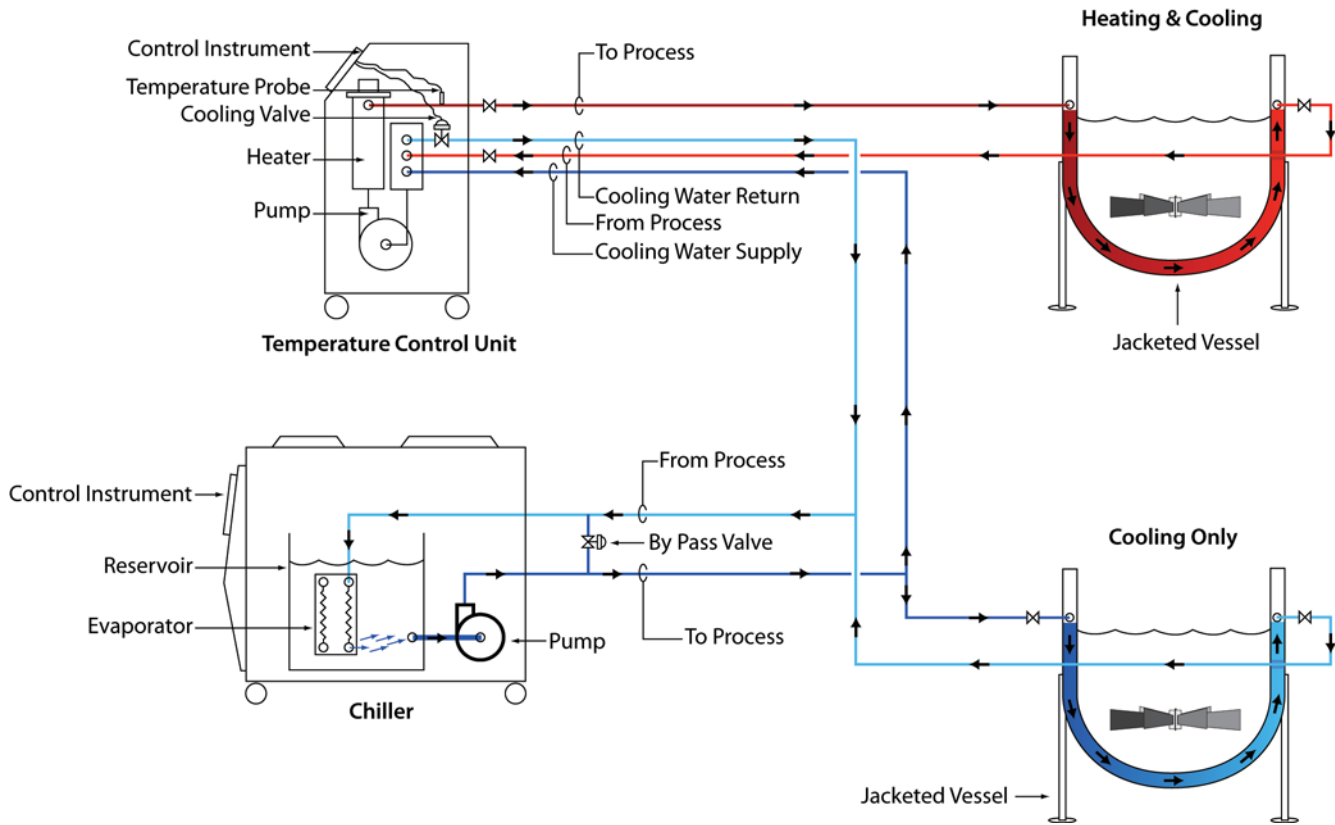

## Once Through Cooling or Heating System

## Entire Plant Cooling Systems

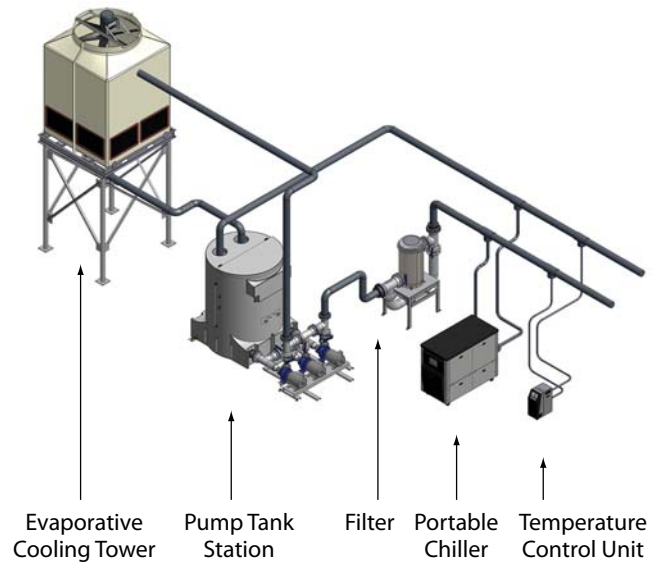
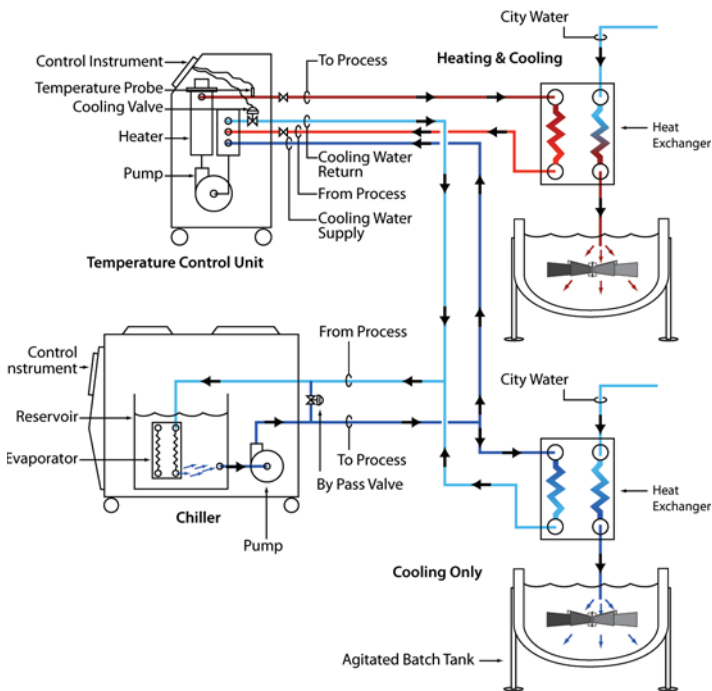

Advantage equipment is not designed for direct contact with food products. Food grade isolation heat exchangers are required.



ADVANTAGE PRODUCTS: TEMPERATURE CONTROLLERS · PORTABLE CHILLERS · CENTRAL CHILLERS · PUMP TANK STATIONS · TOWER SYSTEMS · FILTERS